



IMT Conference

TXMF – Domestic Operations Task
Force Commander
BG Patrick Hamilton

UNCLASSIFIED//FOUO



Agenda

- Mission
- Organization
- All Hazard Operations Plan
- Planned Capabilities
- Operational Approach
- Communication Hub
- Questions



Mission

Provide direction and oversight of Texas Military Forces throughout Texas and Federal Emergency Management Agency (FEMA) Region VI during emergencies and disasters as part of Defense Support of Civil Authorities (DSCA) or civil support operations to save lives, alleviate suffering and protect property. When authorized, provide mission command of Title 32 and Title 10 forces within a Dual Status Command for immediate and long term DSCA response at the request of the Governor of Texas.



JFHQ Texas Organization

TAG's Personal and Special Staff

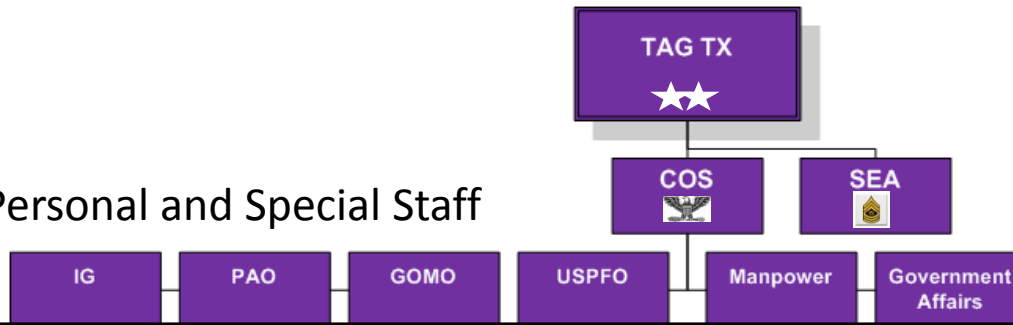

DAG Army ★★

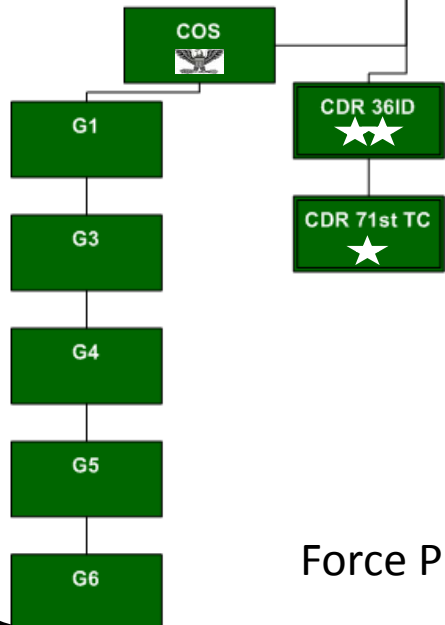

Force Providers

DAG Air ★★

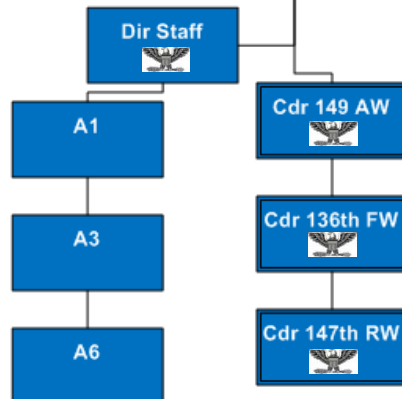

DOMOPS TF Cdr, DJS ★

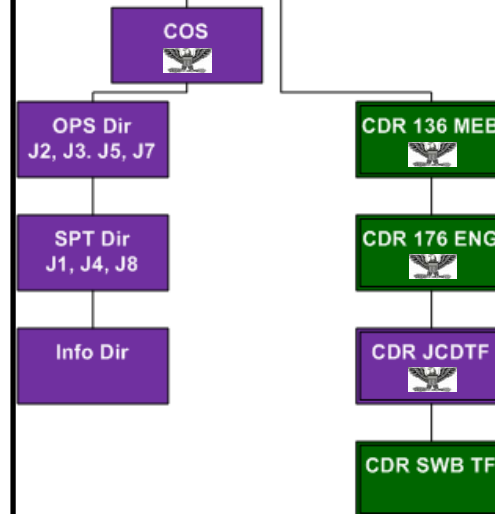

Operational HQ



Key Leaders

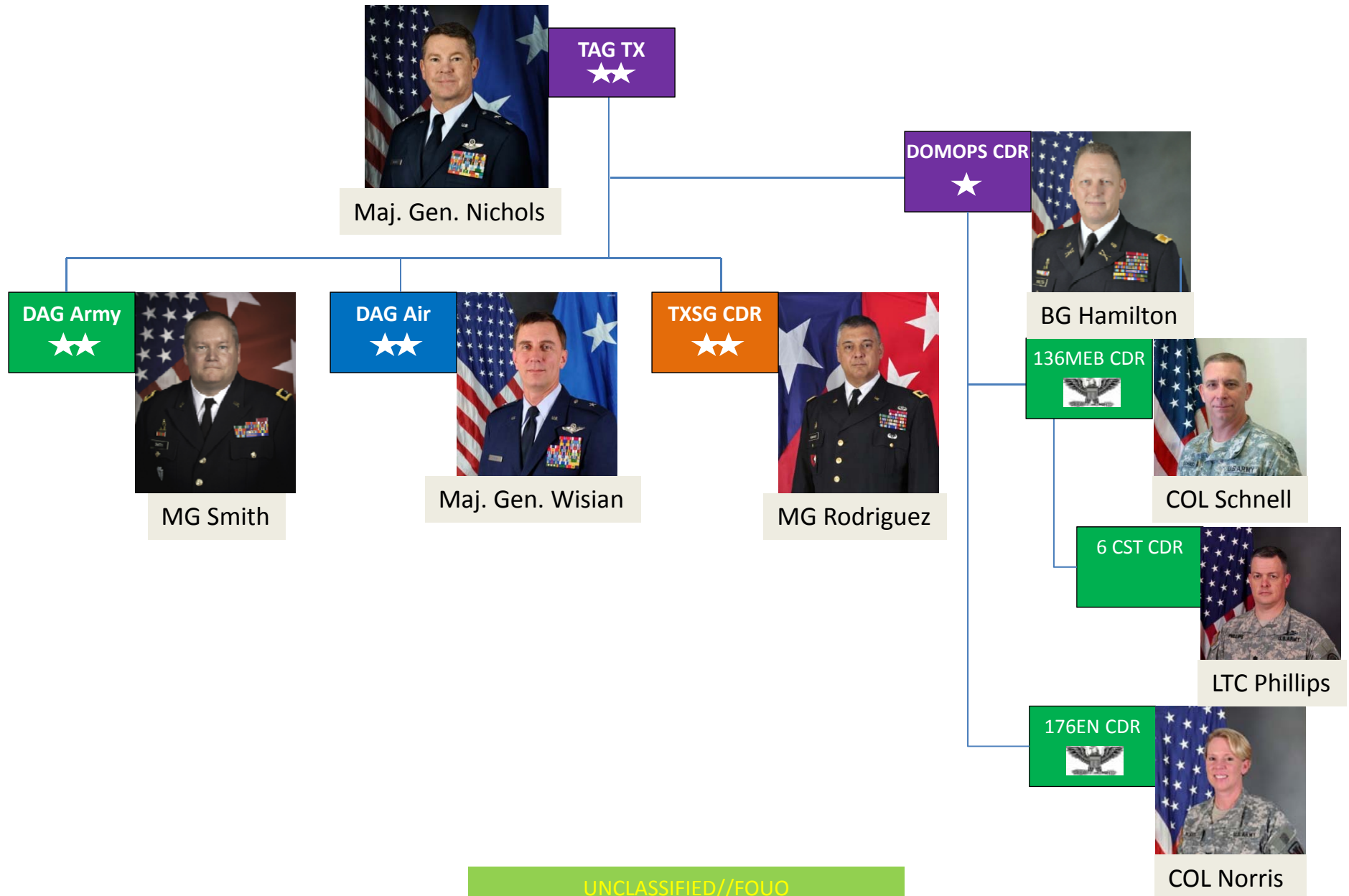



DOMOPS Array of Elements

SCALE 1:2,700,000

UNCLASSIFIED / FOUO

DOMOPS UNIT LOCATION

TEXAS SPECIAL / SHEET 1 / EDITION 1

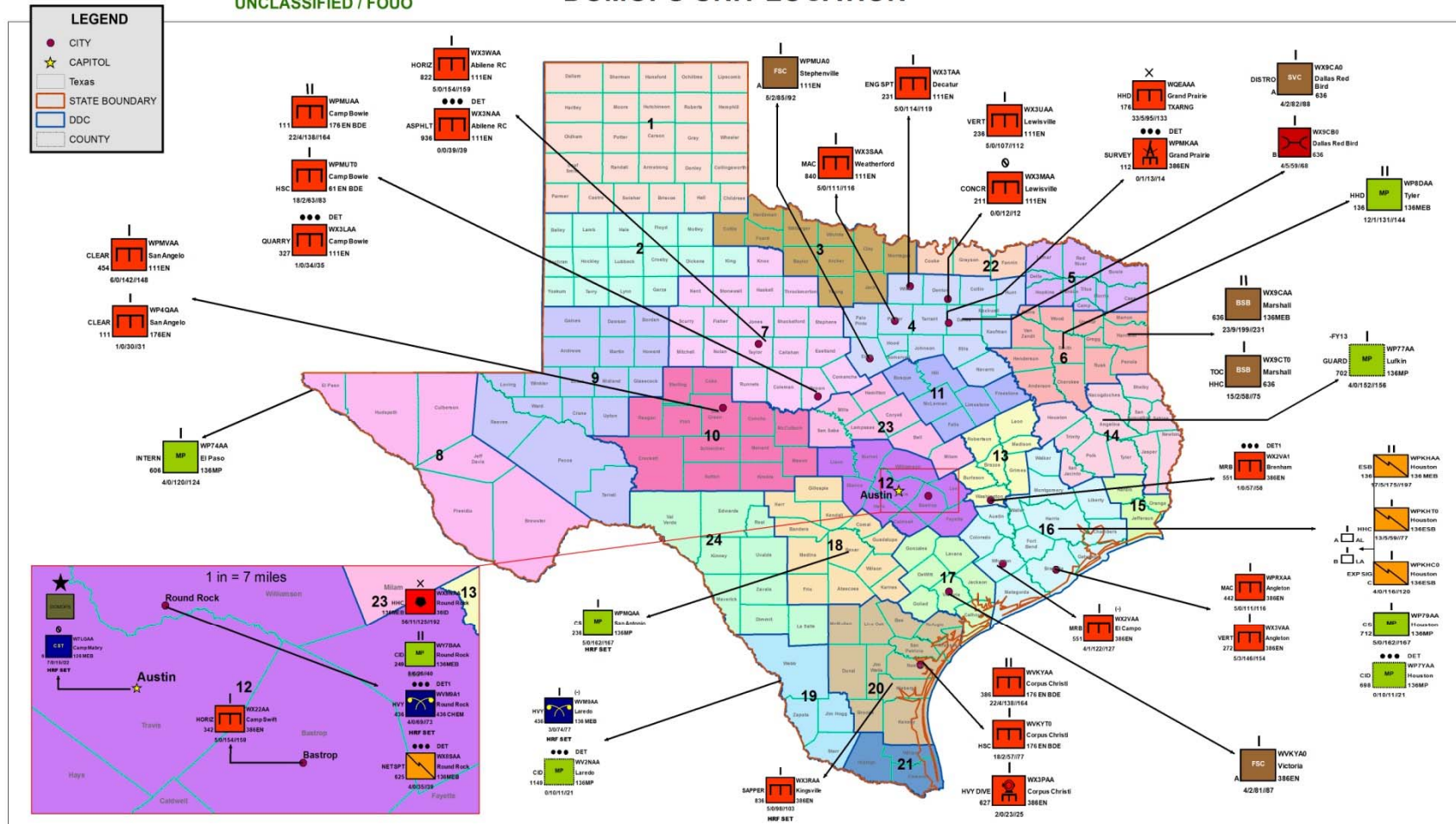

PRODUCTION NOTE:
SFC RONALD F. ROHRIS
03 JULY 2013

PROJECTION NOTE:
SPHEROID..... GCS WGS 1984
PROJECTION..... WGS-1984
DATUM..... D-WGS-1984

UNCLASSIFIED / FOUO

UNCLASSIFIED//FOUO



The All - Hazards Plan



Mission:

TXMF responds in support of civil authorities in order to protect the lives and property of the people of Texas from the effects of natural hazards, criminal enterprises, terrorist threats, cyber threats, and industrial related incidents in support of the Governor of Texas.

TXMF provides prompt, professional, response to All Hazards when ordered by the Governor of Texas or the President of the United States. TXMF trains, coordinates, and deploys to operational environments that are aligned with the Texas Disaster District Map. While executing civil support missions, TXMF units report to Joint Force Headquarters Texas (JFHQ-TX) through the Joint Operations Center (JOC) or the assigned Joint Task Force (JTF) in support of the incident commander in the affected Disaster District.

Commander's Intent:

**OPLAN 14-01
ALL HAZARDS**





Branch Plans Annex C (Operations)

- Storm Season Branch Plan
- CBRN Branch Plan
- Small-Medium Natural Hazards Branch Plan
- Spill Over Violence Branch Plan
- Cyber Incident Branch Plan
- Drought Response Branch Plan
- Planned Event Branch Plan
- JRSOI Branch Plan
- COOP Branch Plan
- No Notice Event Branch Plan

Lead Agency: DPS

Operational Focus:



- Security (presence only)
- Logistical Support
- Aviation Support
- Public Affairs

Plan Status: Complete

Last Update: 2011

Comments:

- Hasty presence within six hours of notification.
- Maintain presence for 72 hours until deliberate response mobilized.



UNCLASSIFIED//FOUO

All Hazards Branch Plans

- Planning conducted for more rapid execution
- Coordinated with TDEM (Joint Planner)
- Synchronized with Army and Air Components
- Updated on regular basis





Planned Capabilities

1 AERIAL TRANSPORTATION [ROTARY WING LIGHT (UH-60/LUH-72)] (TXARNG)																
a. TASK AND PURPOSE.	b. MISSION.															
Task: 1 AERIAL TRANSPORTATION [ROTARY WING HEAVY (CH-47)] (TXARNG)	Provide utility helicopter support to civil authorities.															
a. TASK AND PURPOSE.	b. MISSION.															
1 FERRY/BRIDGE (TXARNG)																
a. TASK AND PURPOSE.	b. MISSION.															
1 Conduct ferry (raft) and bridge operation with	1 Assist with Swift Water Rescue Mission															
1 MULTI-FUNCTION (TXARNG)																
A TASK AND PURPOSE.	b MISSION.															
Task: <ul style="list-style-type: none"> Ground Evacuation Hub support Point of distribution (POD) support Resource Staging Area (RSA) support State Staging Area (SSA) support Temporary Fuel Location (TFL) support Litter bearers for Aero Medical Evacuation operations Conduct high water rescue evacuations Severe winter weather search and rescue 	Provide manpower and multipurpose vehicles in support of civil authorities during a natural and/or manmade disaster.															
Purpose: Provide versatile force package that can support multiple state mission sets enabling dynamic tasking.																
c ESFs: 6,7,9	d LIMITATIONS: <ul style="list-style-type: none"> Can only self sustain for up to 72 hours without re-supply. 															
e PERSONNEL:	f EQUIPMENT:															
<table border="1"> <thead> <tr> <th>SQD MRP</th> <th>PLT MRP</th> <th>Company MRP</th> </tr> </thead> <tbody> <tr> <td> <ul style="list-style-type: none"> 1 SQD LDR (E6/E7) 3 HMMWV DRVR 4 Truck DRVR 3 Team members </td> <td> <ul style="list-style-type: none"> 1 PLT HQ 1 PL 1 PSG 2 HMMWV DRVR 1 Medic 2 Squads </td> <td> <ul style="list-style-type: none"> 1 Company HQ 1 CO 1 ISG 2 DRVR 1 Supply SGT 1 Supply Clerk 1 Medic 2 Fuel Handlers 2 Mechanics 3 PLT </td> </tr> <tr> <td>Total: 11 Soldiers</td> <td>Total: 27 Soldiers</td> <td>Total: 92 Soldiers</td> </tr> </tbody> </table>	SQD MRP	PLT MRP	Company MRP	<ul style="list-style-type: none"> 1 SQD LDR (E6/E7) 3 HMMWV DRVR 4 Truck DRVR 3 Team members 	<ul style="list-style-type: none"> 1 PLT HQ 1 PL 1 PSG 2 HMMWV DRVR 1 Medic 2 Squads 	<ul style="list-style-type: none"> 1 Company HQ 1 CO 1 ISG 2 DRVR 1 Supply SGT 1 Supply Clerk 1 Medic 2 Fuel Handlers 2 Mechanics 3 PLT 	Total: 11 Soldiers	Total: 27 Soldiers	Total: 92 Soldiers	<table border="1"> <thead> <tr> <th>Per SQD Equipment</th> <th>Per PLT Equipment</th> <th>CO HQ Equipment</th> </tr> </thead> <tbody> <tr> <td> <ul style="list-style-type: none"> 2 HMMWV 2 Cargo Trucks (LMTV or equivalent) 4 SINGCARS Other organic communications equipment </td> <td> <ul style="list-style-type: none"> 6 HMMWV 4 Cargo Trucks 1 Water Buffalo 2 Generators 10 SINGCARS Other organic communications equip. External Communications Spt DSCA cell phones from J6 </td> <td> <ul style="list-style-type: none"> 2 HMMWV 1 Cargo Truck 1 Fueler 1 Wrecker 1 Water Buffalo 5 SINGCARS Other organic communications equip. External Communications Support DSCA cell phones from J6 </td> </tr> </tbody> </table>	Per SQD Equipment	Per PLT Equipment	CO HQ Equipment	<ul style="list-style-type: none"> 2 HMMWV 2 Cargo Trucks (LMTV or equivalent) 4 SINGCARS Other organic communications equipment 	<ul style="list-style-type: none"> 6 HMMWV 4 Cargo Trucks 1 Water Buffalo 2 Generators 10 SINGCARS Other organic communications equip. External Communications Spt DSCA cell phones from J6 	<ul style="list-style-type: none"> 2 HMMWV 1 Cargo Truck 1 Fueler 1 Wrecker 1 Water Buffalo 5 SINGCARS Other organic communications equip. External Communications Support DSCA cell phones from J6
SQD MRP	PLT MRP	Company MRP														
<ul style="list-style-type: none"> 1 SQD LDR (E6/E7) 3 HMMWV DRVR 4 Truck DRVR 3 Team members 	<ul style="list-style-type: none"> 1 PLT HQ 1 PL 1 PSG 2 HMMWV DRVR 1 Medic 2 Squads 	<ul style="list-style-type: none"> 1 Company HQ 1 CO 1 ISG 2 DRVR 1 Supply SGT 1 Supply Clerk 1 Medic 2 Fuel Handlers 2 Mechanics 3 PLT 														
Total: 11 Soldiers	Total: 27 Soldiers	Total: 92 Soldiers														
Per SQD Equipment	Per PLT Equipment	CO HQ Equipment														
<ul style="list-style-type: none"> 2 HMMWV 2 Cargo Trucks (LMTV or equivalent) 4 SINGCARS Other organic communications equipment 	<ul style="list-style-type: none"> 6 HMMWV 4 Cargo Trucks 1 Water Buffalo 2 Generators 10 SINGCARS Other organic communications equip. External Communications Spt DSCA cell phones from J6 	<ul style="list-style-type: none"> 2 HMMWV 1 Cargo Truck 1 Fueler 1 Wrecker 1 Water Buffalo 5 SINGCARS Other organic communications equip. External Communications Support DSCA cell phones from J6 														
g REQUIRED SUPPORT:	h WORKS WITH: Works with supported incident commander dependent upon mission assignment.															
i N-HOUR SEQUENCE: N+12 = Squad departs Army N+24 = Platoon departs Army N+36 = Company departs Army	j SPECIAL INSTRUCTIONS: When assigned severe winter weather mission <ul style="list-style-type: none"> Tire chains needed to be issued to assigned unit(s) prior threat period. Cargo trucks need canopies installed When assigned high water evacuation support <ul style="list-style-type: none"> Personal flotation device (PFT) needed per team member 															
k COST PER DAY: PERSONNEL: \$1,650.00(SQ)/\$4,050.00(PL) \$13,800.00(CO) MEALS: \$396.00(SQ)/\$972.00(PL)/\$3,312.00(CO) MRE: \$298.50(SQ)/\$698.50(PL)/\$2,288.50(CO) TRAVEL: \$618.00(SQ)/\$1,442.00(PL)/\$4,738.00(CO)	COST PER HOUR: EQUIPMENT: \$1.26(PL)/\$3.78(CO) COST PER MILE: EQUIPMENT: \$7.62(SQ)/\$19.84(PL) \$70.71(CO)															

Mission Ready Packages

- Task and Purpose
- Mission
- Supported ESFs
- Limitations
- Personnel
- Equipment
- Required Support
- Works with
- N-Hour Sequence
- Special Instructions
- Cost Estimates



TXMF Storm Season Response Timeline

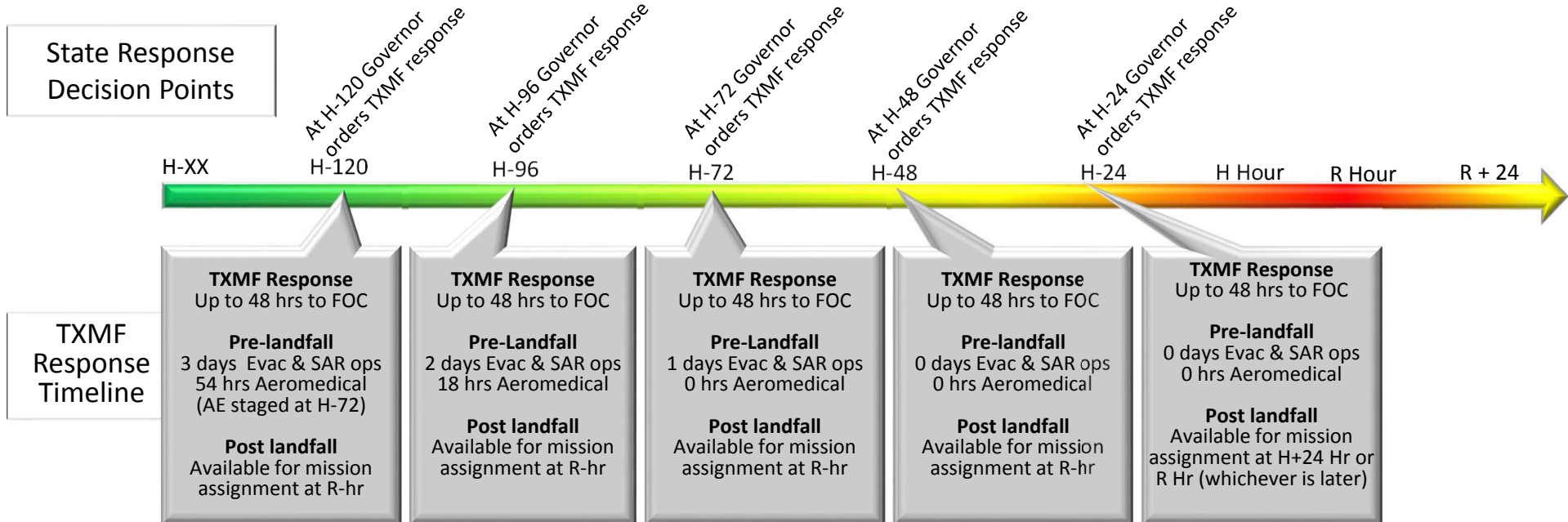

- Storm Season Response Task Force**
- Unit size: Brigade Task Force
 - # Pax: 1949-3046 Soldiers/Airmen
 - SAR - Yes
 - Rotary Aviation - Yes
 - Airlift (Cargo/Personnel) - Yes
 - Airlift (Aeromedical Evac) - Yes
 - Air Evac Hubs - Yes
 - Ground Evac Hubs - Yes
 - Fuel Points - Yes
 - Shelters - Yes
 - PODs - Yes
 - MCST - Yes

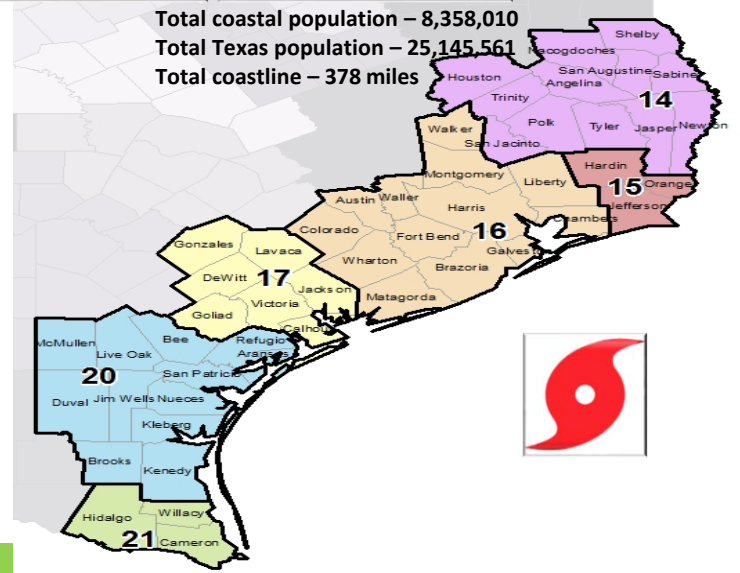

UNCLASSIFIED//FOUO



Platoon/Company Force Package

Small to medium response

- Platoon organized in 2 Squads
 - 27 Personnel / 10 Vehicles
- 3 Platoons deploy with a Company for command and control
 - Administrative and Logistic support
 - 92 Personnel / 35 Vehicles
- MDC deploys at request of DDC
 - Adds planning capability
 - Synchronizes operations with BN
- Response time
 - Time to alert / Assemble
 - Movement to site
- Communications
 - UHF/VHF
 - Cell (GPS)

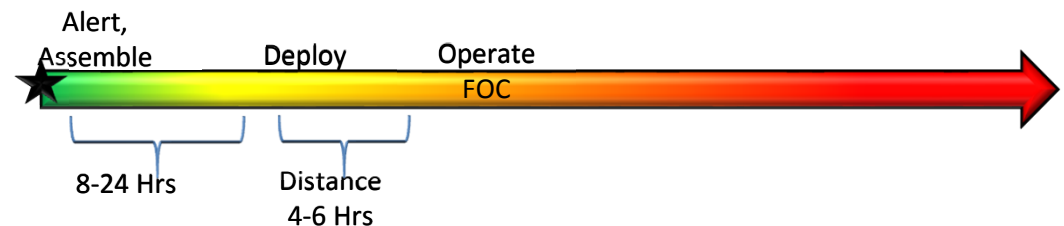
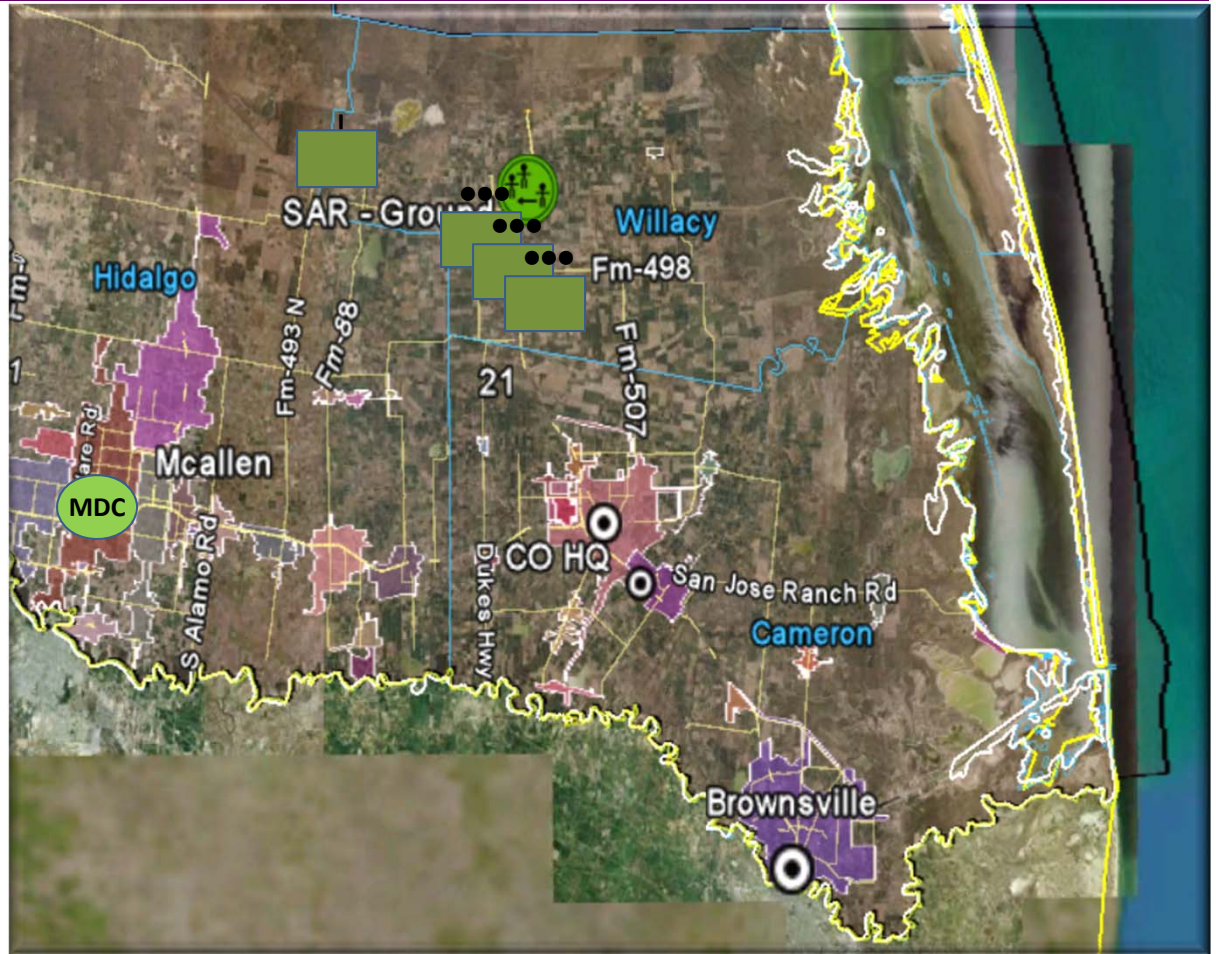

UNCLASSIFIED//FOUO



Battalion Force Package

Medium to large response

- 3 Companies or more deploy with a BN Headquarters
 - Administrative and Logistic support
 - 303 Personnel / 111 Vehicles
- MDC deploys at request of DDC
 - Adds planning capability
 - Synchronizes operations with JOC
- Response time
 - Time to alert / Assemble
 - Movement to site
- Communications
 - TICP (Satellite)
 - Internet
 - UHF/VHF
 - Cell (GPS)

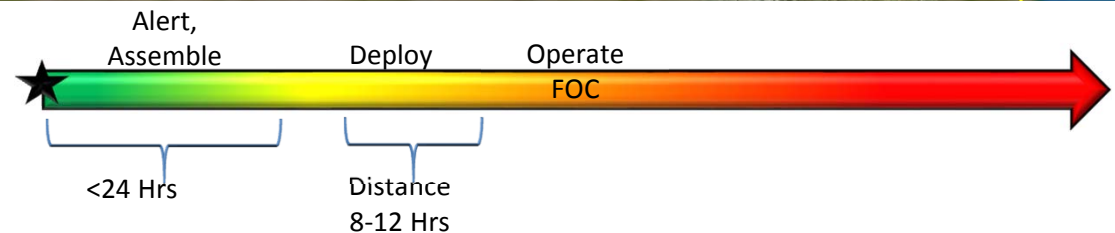
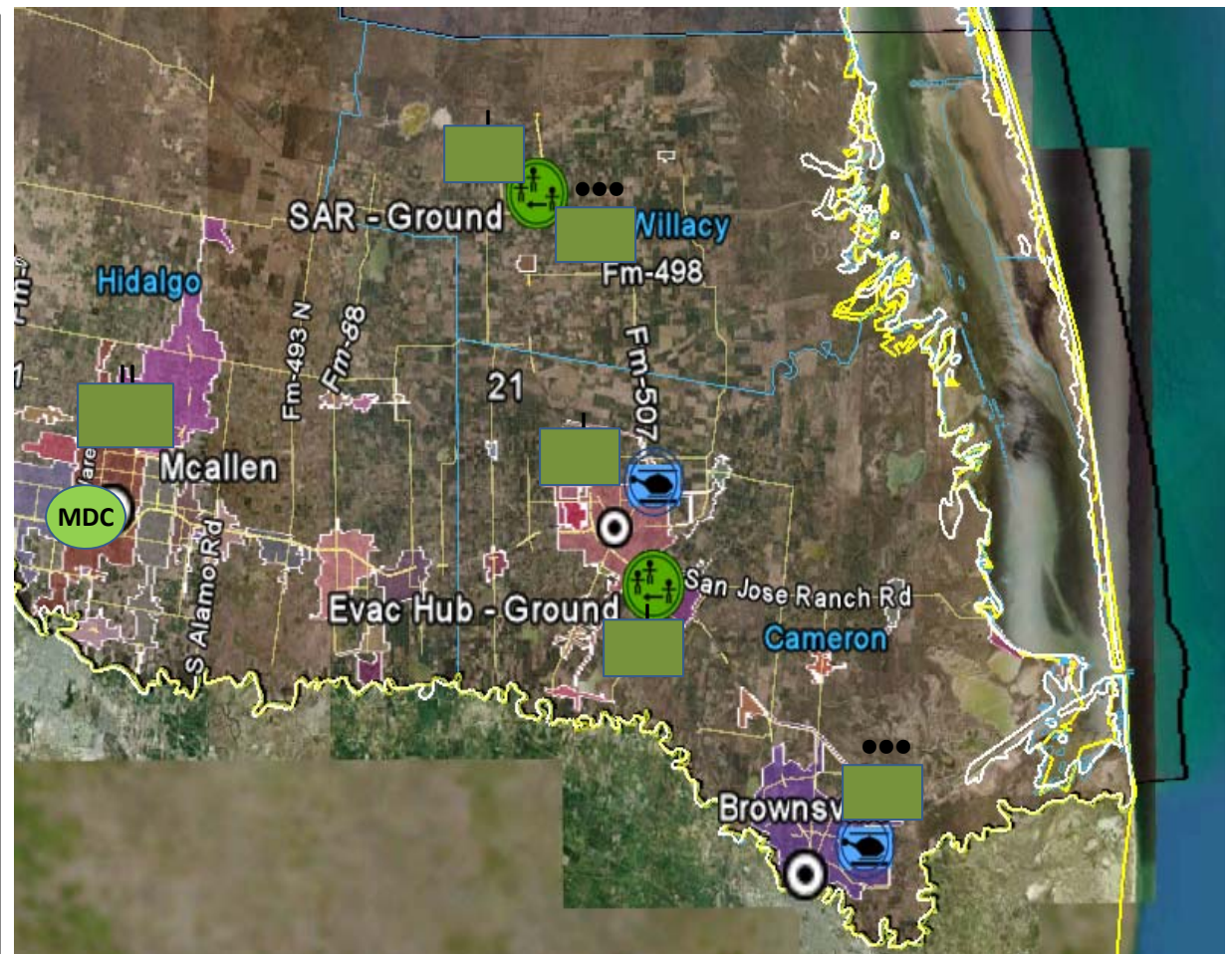

UNCLASSIFIED//FOUO



JTF (Brigade) Force Package

Large response

- 3 Battalions or more deploy with a JTF Headquarters
 - Administrative and Logistic support
 - 1000 Personnel / 400 Vehicles
- MDC(s) deploys at request of DDC(s)
 - Adds planning capability
 - Synchronizes operations with JTF
- Response time
 - Time to alert / Assemble
 - Movement to site
- Communications
 - (3) TICP (Satellite)
 - JISCC (Satellite)
 - Internet / VTC
 - UHF/VHF
 - Cell (GPS)
 - MSAT / Iridium Phone

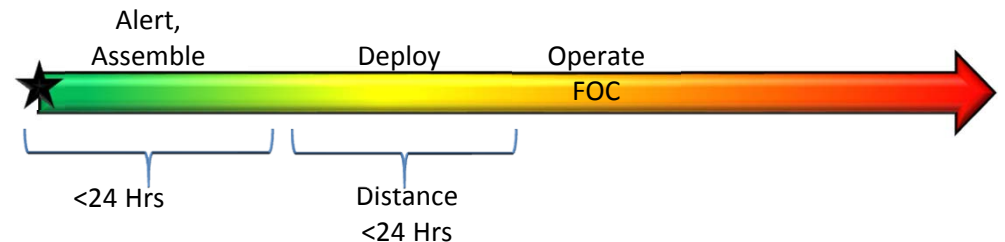
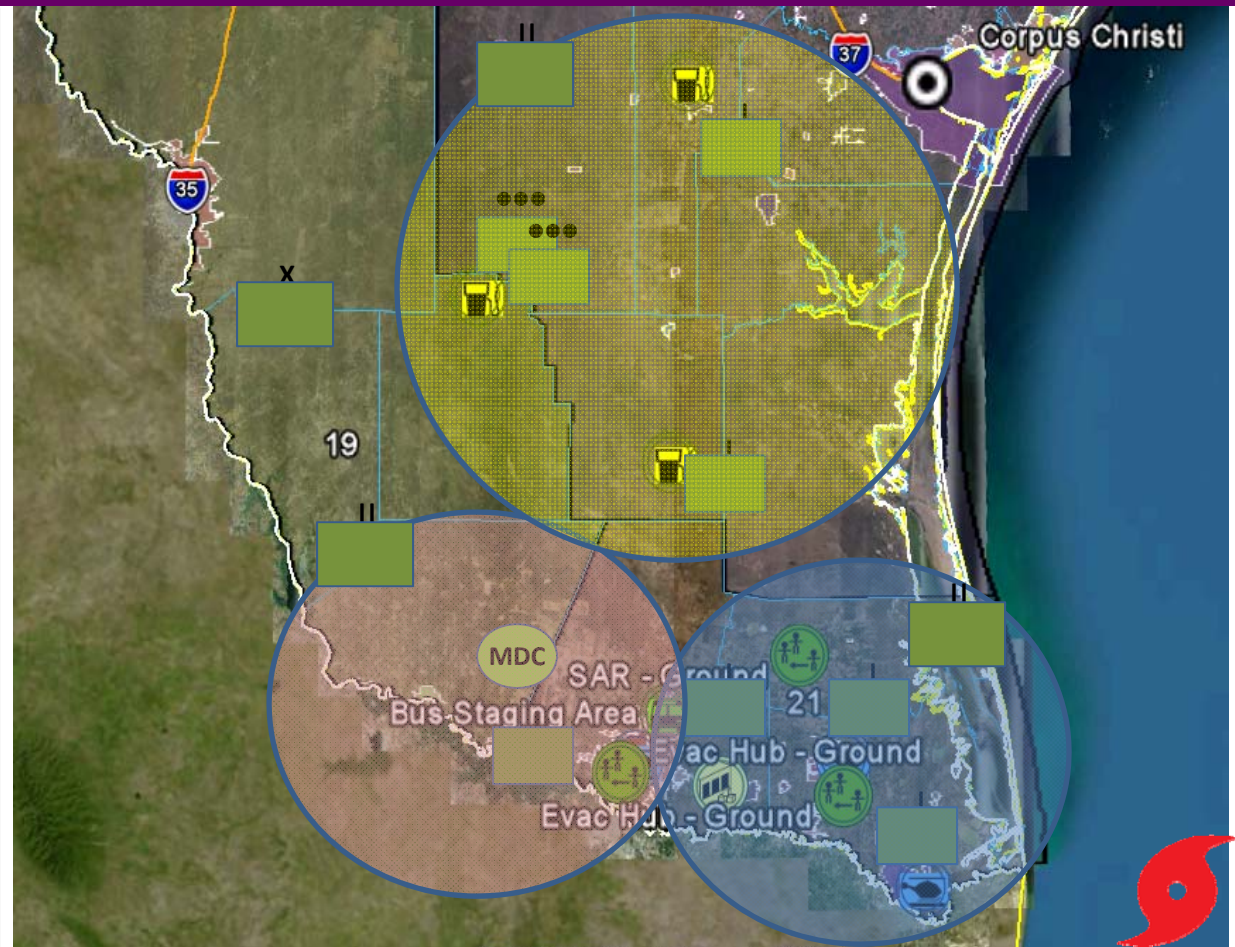

UNCLASSIFIED//FOUO



MDC Duties and Responsibilities

The Military District Coordinator (MDC) will serve as the coordinating element for all military units conducting DSCA or Civil Support operations within the disaster district and facilitate their tactical and logistical support until a Force Package C2 element deploys to the disaster district (DD). MDCs must analyze their respective Disaster District Data (3D). Below are the five phases that the Texas Military Forces (TXMF) will undergo during an emergency or disaster.

Phase 0 Steady State: MDC maintains proficiency by reviewing the All Hazards Plan, maintains DSCA Situational Awareness within the Disaster District, liaisons with the Disaster District Coordinator (DDC), attends the Defense Support to Civilian Authorities (DSCA) Liaison Officer Course, and establishes relationships with local commander(s).

Phase I Anticipate: MDC is notified of impending incident and given initial activation instructions. The MDC contacts the Joint Operations Center (JOC) for STAR report information and guidance. The MDC may also recommend the local unit dispatch an LNO to the DDC (Coordinator or Chairman) if warranted.

Phase II Respond: MDC provides low level C2 over 1-2 Force Packages (FPs) deployed to the DD and coordinates through the JOC.

Phase III Operate and Phase IV Stabilize: MDC receives and consolidates required reports from FP's and forwards consolidated reports to the JOC. MDC coordinates with FPs and JOC to support FPs tactically and logistically.

Phase V Redeployment: MDC coordinates movement of FP's with the JOC and ensures the JOC is aware of when the MDC vacates the DD.

The MDC may be asked to provide an LNO to the DDC (Coordinator or Chairman) in addition to the MDC. This LNO will be located at the DD Emergency Operations Center (EOC) when requested.



Joint Operation Center

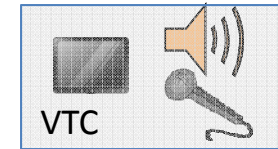

VTC

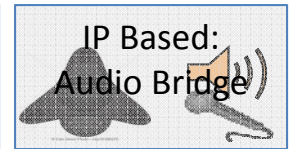

IP Based:
Audio Bridge



Critical Requirements

- Receive, action and distribute all information, orders and reports (internal and external)
- Develop, maintain and display an accurate operational picture for planning and CDR decision making
- Share a Common Operating Picture (COP) with all units, adjacent agencies, and other stakeholders
- Initiate planning for projected TXMF responses or missions

Configuration

- Stadium seating for 28 LNOs or inter-agency reps.
- Commercial/Military internet
- IP/SAT/SIPR Phones
- HF/UHF/VHF/800Mhz Radios
- Audio / Video meeting capable
- Media Wall 12 configurable monitors display current operations
- Wall monitors – monitor environment for changes

UNCLASSIFIED//FOUO



Defense Connect Online (DCO)

Viewable by JOC, JTF, BN, MDCs or Inter-Agency Partners with Internet Connectivity

The screenshot displays the DCO interface with several panels:

- Daily Update Brief:** Contains sections for BLUE, SITUATION, Whole of Government Response, NGR Response, State of Texas Response, TXMF Response, MISSIONS, Recent RFAs, Recent RFI, Daily NWS Threat Brief, and Saturday.
- Map:** A geo-spatial map of Texas and surrounding areas showing flood levels (OPF in inches) with a color-coded legend ranging from 0.01 to 18.00 inches.
- Attendee List (7):** Lists participants including MORAN, BRIAN S 1LT USA, WYLIE, CHASE A SGT JOINT STAF..., DIAZ, MICHAEL J MSgt USAF USA..., Blade 4 - guest 2, blade 5 - guest, guest - guest, and MAJ Mancuso - guest.
- Recently Published Orders:** A table listing various orders with columns for Name and Size.
- JOC Calendar - next 72 hrs:** Shows a calendar with events for 26 OCT 2013 (DRILL), 27 OCT 2013 (DRILL), 28 OCT 2013 (0900 - OPS Directorate 90 day Calander Sync - JOC Conf Table), and 29 OCT 2013.
- JFHQ-Ops Chat (Everyone):** A chat window for real-time communication.

- Adobe platform (Mobile available)
- Incident Communications (Chat)
- Share-out Live Feed of JOC Geo-Spatial Images
- File Sharing
- Video Conferencing (Shared presentations with Audio)



OPs Summary

West Fertilizer Plant Explosion

S: West Fertilizer Plant explosion (VIC West, TX) 171950APR13. (No significant change)
 A: SAR Efforts: TTF 1 and 2 continuing SAR operations.
 – TXDOT established traffic management plan.
 – IC in West reports no un-met needs at this time.
 L: West Fertilizer Plant
 U: 6th CST continuing to monitor for airborne hazards with (15) personnel on site
 – MDC (2) are operating at DDC 11 and ICP
 – LNO (2) is at the SOC
 – PAO (3) supporting the ICP in West.
 T: 1916300APR13
 E: NSTR

Action Taken:

- FRAGO 8 tasked CST and notified DECON/S&E
- FRAGO 9 tasked MDC
- TXMF Soldiers in affected zip codes sent to Components; families all accounted for

Partner Response

- TDEM:
 - SOC Established
 - DPS/DoT Manage Traffic
 - DDC 11 EOC Established
- Federal:
 - FEMA (Standby): IMAT Teams, Crisis Counseling, Mortuary Assist, DMORT moves to DFW today
 - EPA established EOC, employed ASPECT
 - FAA TFR 3 Mi
 - GSA Distribution: Inventorying possible items for deployment
 - Fort Hood: 10 Firefighters and 1 Truck to support
 - **Fort Hood: 7 A/C SMs volunteered support to ICP**

Total PAX Missioned:
 Site: 18 Pax (FTUS)
 SOC: 2 Pax (FTUS)
 MDC: 2 Pax (FTUS)

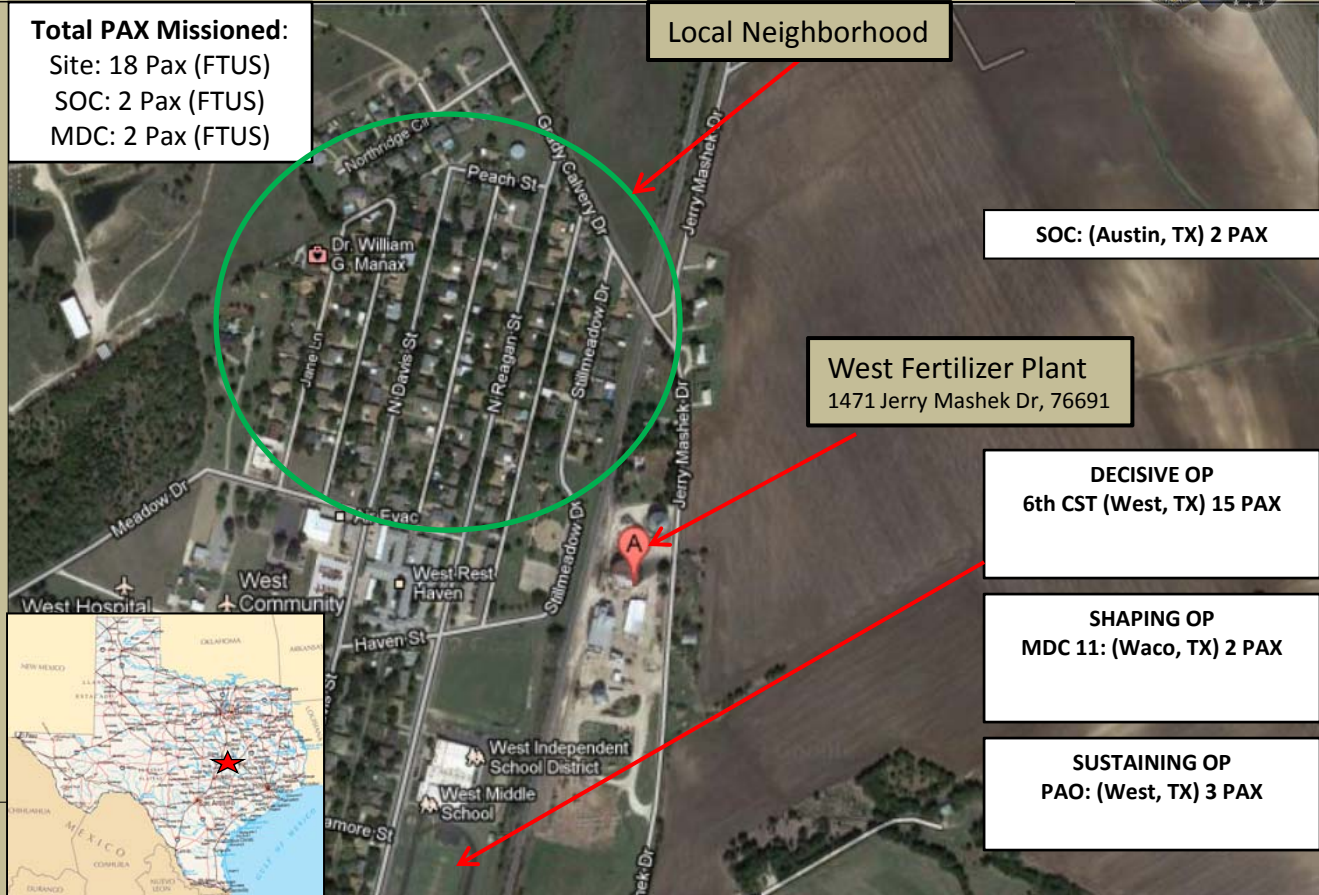

CCIR / Decision Points:

- **Decision #1: Deploy additional forces**
 - CCIR 1.1 - Are additional capabilities required that TXMF can provide
 - CCIR 1.2 - Is Aviation support required
- **Decision #2: Conduct relief operations**
 - CCIR 2.1 – Duration of TXMF missions
 - CCIR 2.2 – STAR for expanded MDC team support (2 Locations/24hrs)

Conditions for success:

- CST Conducts Air Sampling
- Duration expectations:**
- **Next 24:** Continue air sampling.
- **Next 48:** Redeploy CST

Battle Rhythm

- SOC Events:
 - 1400 – State Situation Report
 - 1500 – DDC Situation Reports
 - 1700 – State Situation Report
- TXMF Events
 - 0800 – SALUTE (e-mail) to Leaders / Staff
 - 1000 – Update Brief to All (e-mail)
 - 1330 – DOMOPS CDR CUB
 - 1630 – Update Brief to All (e-mail)



Questions?



STATE OF TEXAS



HURRICANE
RESPONSE PLAN

